

Quad Comparator, High Speed

# RHD5910

## Features

- Single power supply operation at 3.3V or 5.0V
- Radiation performance
  - Total dose: > 1 Mrad(Si); Dose rate = 50-300 rad(Si)/s
  - ELDRS Immune
  - SEL Immune > 100 MeV-cm<sup>2</sup>/mg
  - Neutron Displacement Damage > 10<sup>14</sup> neutrons/cm<sup>2</sup>
- Short Circuit Tolerant
- Full military temperature range
- Designed for aerospace and high reliability space applications
- Packaging – Hermetic ceramic SOIC
  - 16-pin, .417"L x .300"W x .120"Ht
  - Weight - 0.8 grams max
- **Radiation Hardness Assurance Plan: DLA Certified to MIL-PRF-38534, Appendix G.**

## General Description

The RHD5910 is a radiation hardened, single supply, high speed, quad comparator in a 16-pin SOIC package. The RHD5910 design uses specific circuit topology and layout methods to mitigate total ionizing dose effects and single event latchup. These characteristics make the RHD5910 especially suited for the harsh environment encountered in Deep Space missions. It is guaranteed operational from -55°C to +125°C. Available screened in accordance with MIL-PRF-38534 Class K, the RHD5910 is ideal for demanding military and space applications.

## Organization and Application

The RHD5910 quad comparator is intended for operation with dynamic signals on either or both inputs. Comparison is 'continuous', that is, the circuit functions as high gain open loop amplifiers with a digital output. For slow input signals with small input differences the comparators can be expected to respond to small noise signals at the inputs. Feedback hysteresis is the responsibility of the user to avoid 'chattering' on system noise.

The comparator will accept signals anywhere in the included power supply range. The circuit delay is specified for a half-volt single ended or differential input step of either polarity ending in an input polarity reversal of 10mV. See Switching Diagrams.

CMOS device drive has a negative temperature coefficient and the devices are therefore inherently tolerant to momentary shorts, although on chip thermal shutdown is not provided. All inputs and outputs are diode protected.

The devices will not latch with SEU events above 100 Mev-cm<sup>2</sup>/mg. Total dose degradation is minimal to above 1 Mrad(Si). Displacement damage environments to neutron fluence equivalents in the mid 10<sup>14</sup> neutrons per cm<sup>2</sup> range are readily tolerated. There is no sensitivity to low-dose rate (ELDRS) effects. SEU effects are application dependent.

# RHD5910

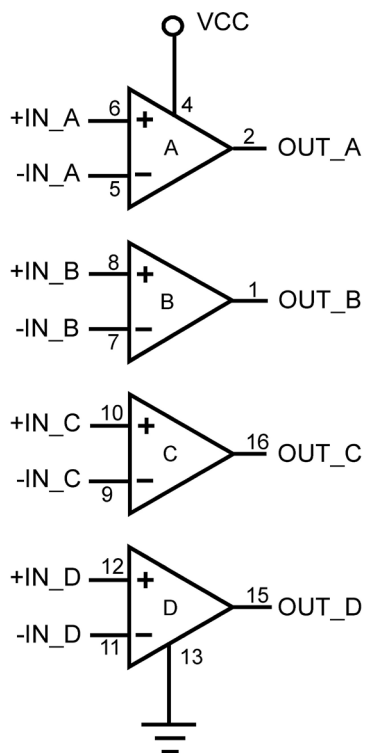
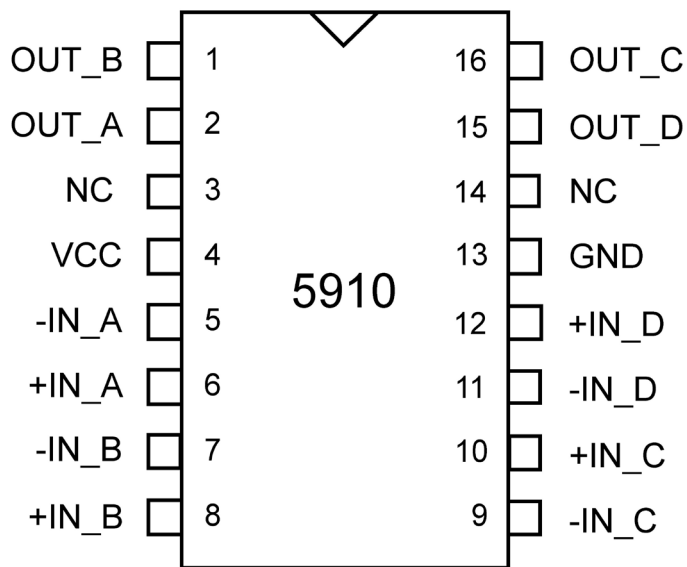

Figure 1: Block Diagram



16-Pin SOIC

Figure 2: Package Pin-Out

**Notes:**

- 1) Package and lid are electrically isolated from signal pads.
- 2) It is recommended that NC or no connect pins (pins 3 and 14) and lid be grounded. This eliminates or minimizes any ESD or static buildup.

Quad Comparator, High Speed

# RHD5910

**Table 1: Pin-Out Description**

Pin #s	Signal	Definitions
1	OUT_B	Output of Comparator B.
2	OUT_A	Output of Comparator A.
3	NC	It is recommended tying this pin to ground
4	VCC	DC Supply Voltage
5	-IN_A	Inverting Input to Comparator A
6	+IN_A	Non-Inverting Input to Comparator A
7	-IN_B	Inverting Input to Comparator B
8	+IN_B	Non-Inverting Input to Comparator B
9	-IN_C	Inverting Input to Comparator C
10	+IN_C	Non-Inverting Input to Comparator C
11	-IN_D	Inverting Input to Comparator D
12	+IN_D	Non-Inverting Input to Comparator D
13	GND	DC Supply Return
14	NC	It is recommended tying this pin to ground
15	OUT_D	Output of Comparator D.
16	OUT_C	Output of Comparator C.

**Absolute Maximum Ratings**

Parameter	Range	Units
Case Operating Temperature Range	-55 to +125	°C
Storage Temperature Range	-65 to +150	°C
Junction Temperature	+150	°C
Supply Voltage +V <sub>CC</sub>	+7.0	V
Input Voltage	V <sub>CC</sub> +0.4 GND -0.4	V V
Lead Temperature (soldering, 10 seconds)	300	°C
Power @ 25°C	250	mW

**Notice:** Stresses above those listed under "Absolute Maximum Ratings" may cause permanent damage to the device. These are stress rating only; functional operation beyond the "Operation Conditions" is not recommended and extended exposure beyond the "Operation Conditions" may affect device reliability.

# RHD5910

## Recommended Operating Conditions

Symbol	Parameter	Typical	Units
+V <sub>CC</sub>	Power Supply Voltage	3.3 to 5.0	V
V <sub>CM</sub>	Input Common Mode Range	V <sub>CC</sub> to GND	V

## Electrical Performance Characteristics

(T<sub>C</sub> = -55°C TO +125°C, +V<sub>CC</sub> = +5.0V -- Unless Otherwise Specified)

Parameter	Symbol	Conditions	MIN	MAX	Units
Quiescent Supply Current <u>1/</u>	I <sub>CCQ</sub>	No Load		15	mA
Input Offset Voltage <u>1/</u>	V <sub>OS</sub>		-60	60	mV
Input Offset Current <u>1/</u> , <u>3/</u>	I <sub>OS</sub>		-1	1	nA
Input Bias Current <u>1/</u> , <u>3/</u>	I <sub>B</sub>		-1	1	nA
Common Mode Rejection Ratio <u>2/</u>	CMRR		50		dB
Power Supply Rejection Ratio <u>2/</u>	PSRR		50		dB
Output Voltage High <u>1/</u>	V <sub>OH</sub>	R <sub>LOAD</sub> = 2 KΩ	4.9		V
Output Voltage Low <u>1/</u>	V <sub>OL</sub>	R <sub>LOAD</sub> = 2 KΩ		0.1	V
Gain <u>2/</u>	A	No Load	5		V/mV
Short Circuit Output Current <u>2/</u>	I <sub>O(SINK)</sub>	V <sub>OUT</sub> to V <sub>CC</sub>	-130	-220	mA
	I <sub>O(SOURCE)</sub>	V <sub>OUT</sub> to V <sub>EE</sub>	130	200	

### Notes:

- 1) Specification derated to reflect Total Dose exposure to 1 Mrad(Si) @ 25°C.
- 2) Not tested. Shall be guaranteed by design, characterization or correlation to other test parameters.
- 3) Subgroup 3 for these parameters is guaranteed, but not production tested.

## Switching Characteristics

(T<sub>C</sub> = -55°C TO +125°C, +V<sub>CC</sub> = +5.0V -- Unless Otherwise Specified)

Parameter	Symbol	Conditions	MIN	MAX	Units
Output Delay	T <sub>OUT</sub>	R <sub>LOAD</sub> = 2 KΩ <u>1/</u>		200	ns

### Note:

- 1) The circuit delay is specified for a half-volt single ended or differential input step, of either polarity, ending in an input polarity reversal of 10mV.

# RHD5910

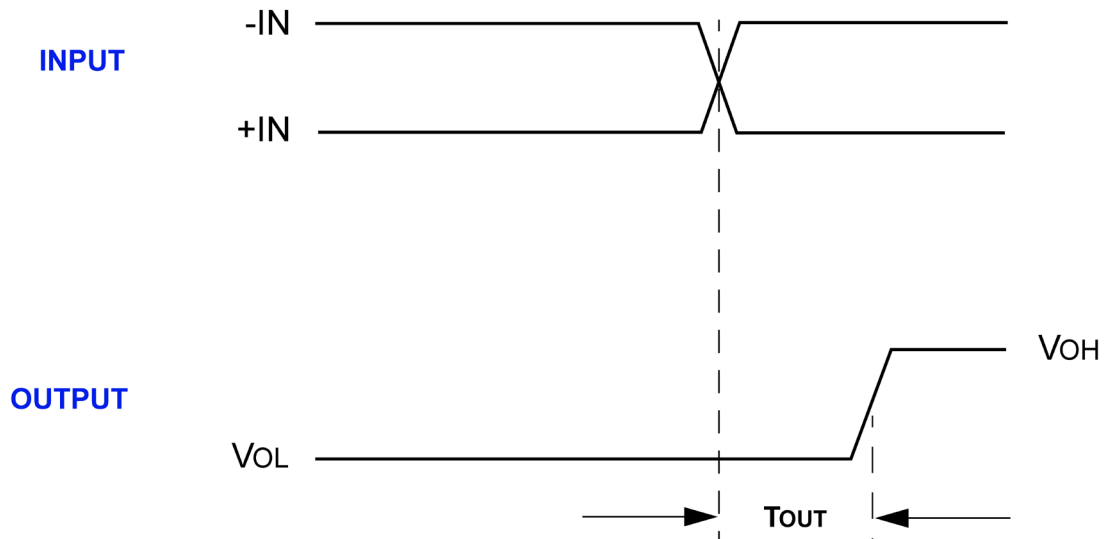

Figure 3: RHD5910 Switching Diagram

## Application Note 1

### Comparator with Hysteresis

#### Threshold Voltage

$$V_{TH} = V_{CC} \frac{R2}{R1 + R2}$$

#### Hysteresis Calculation

$$HYS = V_O \frac{R2}{R2 + R3}$$

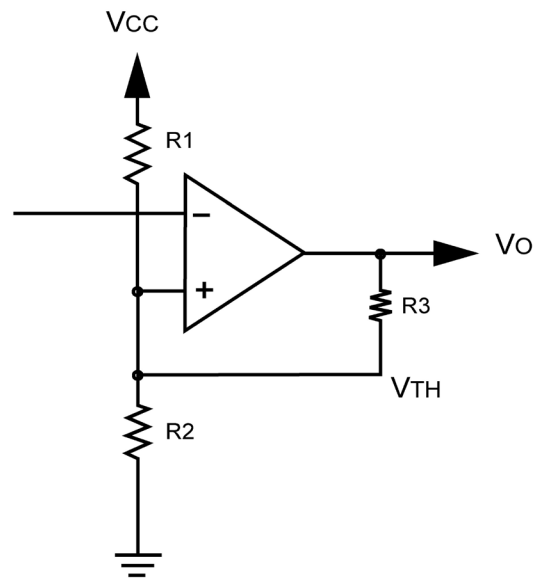

Quad Comparator, High Speed

# RHD5910

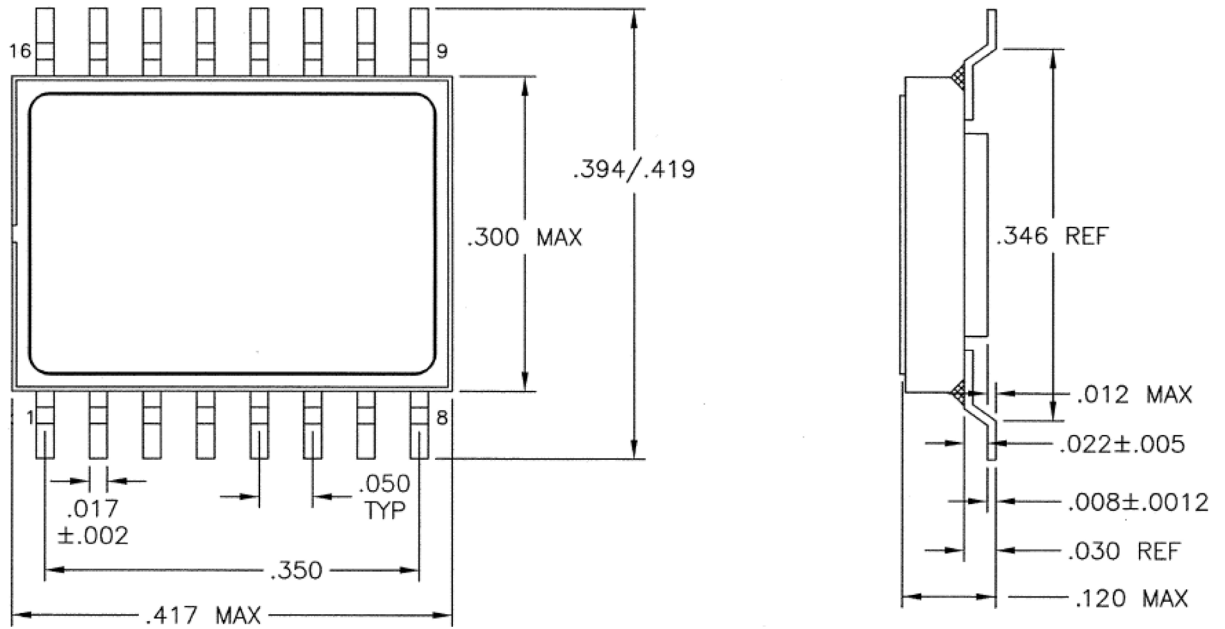

Figure 4: Package Outline

**Note:**

- 1) Package and lid are electrically isolated from signal pads.

### Ordering Information

Model	DLA SMD #	Screening	Package
RHD5910-7	-	Commercial Flow, +25°C testing only	16-pin SOIC
RHD5910-S	-	Military Temperature, -55°C to +125°C Screened in accordance with the individual Test Methods of MIL-STD-883 for Space Applications	
RHD5910-201-1S	5962-1024201KXC	In accordance with DLA SMD	
RHD5910-201-2S	5962-1024201KXA		
RHD5910-901-1S	5962H1024201KXC	In accordance with DLA Certified RHA Program Plan to RHA Level "H", 1 Mrad(Si)	
RHD5910-901-2S	5962H1024201KXA		

Quad Comparator, High Speed

# RHD5910

## Revision History

Date	Revision	Change Description
03/28/2016	G	Import into CAES format



# RHD5910

## Datasheet Definitions

	DEFINITION
Advanced Datasheet	CAES reserves the right to make changes to any products and services described herein at any time without notice. The product is still in the development stage and the datasheet <b>is subject to change</b> . Specifications can be <b>TBD</b> and the part package and pinout are <b>not final</b> .
Preliminary Datasheet	CAES reserves the right to make changes to any products and services described herein at any time without notice. The product is in the characterization stage and prototypes are available.
Datasheet	Product is in production and any changes to the product and services described herein will follow a formal customer notification process for form, fit or function changes.

The following United States (U.S.) Department of Commerce statement shall be applicable if these commodities, technology, or software are exported from the U.S.: These commodities, technology, or software were exported from the United States in accordance with the Export Administration Regulations. Diversion contrary to U.S. law is prohibited.

Cobham Long Island Inc. d/b/a Cobham Advanced Electronic Solutions (CAES) reserves the right to make changes to any products and services described herein at any time without notice. Consult an authorized sales representative to verify that the information in this data sheet is current before using this product. The company does not assume any responsibility or liability arising out of the application or use of any product or service described herein, except as expressly agreed to in writing; nor does the purchase, lease, or use of a product or service convey a license under any patent rights, copyrights, trademark rights, or any other of the intellectual rights of the company or of third parties.