

BEU8635-08

Description

The CAES 8635-08 is a Lithium-Ion cell balancing system. It controls the balancing of one battery consisting of a series stack of Lithium-Ion cells to ensure that each cell is precisely charged to its proper level of energy and to monitor each cell's operational voltage.

The cell balancing circuitry uses a set of bilateral DC-DC converters which tie each cell of a battery to a common share bus. Cell charge is distributed among the multiple cells so that the charge of each cell is automatically matched to the average charge of the other cells.

Features

- Cell Balancing to within $\pm 5.0\text{mV}$
- Cell Voltage Monitoring Accuracy $\pm 10.0\text{mV}$ ($\pm 20.0\text{mV}$ Space Mission Life)
- Total Battery Voltage Monitoring Accuracy $\pm 0.3\%$ of Full Scale
- Supports 8 Lithium-Ion battery cells in series
- Battery Drain Current at Balance 15mA maximum
- Discrete output lines for critical signaling with user definable thresholds:
 - Overvoltage Protection 4.40V typ
 - Cell Voltage High 4.20V typ
 - Cell Voltage Low 3.20V typ
- MIL-STD-1553B telemetry for data logging and monitoring



BEU8635-08

Safety

The safety of Lithium-Ion battery technology requires that extreme care be taken in the provisions made for cell charging and cell monitoring.

Precision measurements of each of the individual cell voltages in the battery stack and precise charge balancing to each individual cell are critical.

The CAES 8635-08 provides the necessary precision of control and monitoring to ensure that safety.

Discrete logic outputs are provided for critical signaling, enabling the user to initiate load shedding and/or to halt charging.

Low operating losses enable continuous operation. Continuous balancing provides maximum protection against any one cell becoming overcharged.

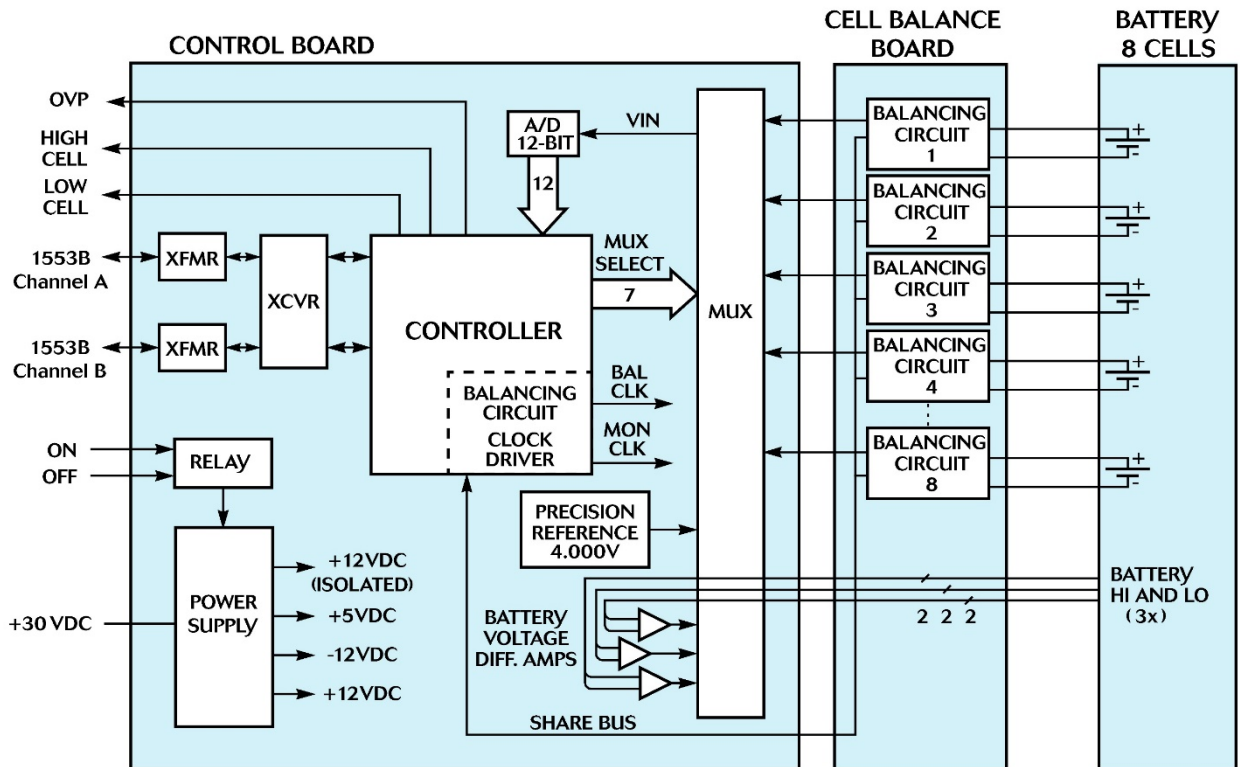

Block Diagram

Balancing for 8-Cell Battery Cell Voltage Monitoring and Telemetry

BEU8635-08

8635-08 Operating Details

Battery Cell Balancing

Provides 8 individual continuous balancing circuits.

Maximum Cell Balancing Current Limit

Each cell is provided with a 1Amp fuse for overload interrupt in the event of a shorted cell to protect the remaining cell balance functionality.

Cell Balancing Accuracy

When connected to a battery, the 8635-08 provides balancing currents into each of the battery's cells. The directions and the magnitudes of the individual currents are proportional to the deviations of the cell voltages from the average cell voltage. The transfer ratio of voltage to current is 1.0 Ohm nominal and is satisfied for cell voltages of up to 4.2V.

Battery Cell Current Drawn in Off State

In the off state, the differential mode battery cell current drawn by each cell balancing circuit is less than 50 μ A.

Battery Cell Voltage Monitoring

Measures cell voltages for up to 8-cells.

4V and 0V References for Calibration

Provides 4V and 0V references for cell voltage telemetry calibration.

Battery and Cell Protection

Incorporates overvoltage protection (OVP) circuits. These circuits monitor all of the battery cell voltages and only register the highest of all cell voltages monitored. When a cell voltage threshold of 4.40V is reached, the protection circuit output changes state and latches within 50mS.

Battery Cell Overvoltage Latch Output

The status of the OVP latch is provided by telemetry as specified in Tables II, III & IV and also as a discrete output.

Recovery from Cell Overvoltage Indication

The OVP latch is reset by a 1553B reset command or by recycling the input power.

Highest Battery Cell Voltage Telemetry

Provides highest battery cell voltage telemetry as specified in Tables I & IV.

Lowest Battery Cell Voltage Telemetry

Provides lowest battery cell voltage telemetry as specified in Tables I & IV.

Balancing for 8-Cell Battery Cell Voltage Monitoring and Telemetry

BEU8635-08

Test Points

Provides test points for total battery voltage, low cell indicator and high cell indicator. Access to the total battery voltage is provided to permit pre-charging before connection to the battery.

MIL-STD-1553B Telemetry & Commands

Analog or bi-level telemetry can be requested from the controller and reported over the dual redundant 1553B interface with the RT addresses configurable at the J1 connector.

Analog Telemetry

Each analog telemetry item can be requested individually on sub-addresses 18, 19 or 22.

First a 1553B receive command with one data word as defined in Table I, which specifies the telemetry item being requested, must be issued. After a minimum delay of 1.2ms, the data can be retrieved by sending a 1553B transmit command for one data word on the same sub-address on which the request was initiated.

The 12-bit data reply is left justified in the 16-bit 1553B data word with the four LSBs set to "0".

Table I – Analog Telemetry

Item	Telemetry Title	Telemetry Reply Scale	1 st Data Word of 1553B Receive Command (Hex)
1	4V Reference	-0.40V to 4.89V	0800
2	0V Reference	-0.40V to 4.89V	0803
3	Total Battery Voltage 1	0V to 122.88V	0805
4	Total Battery Voltage 2	0V to 122.88V	0806
5	Total Battery Voltage 3	0V to 122.88V	0809
6	Share Bus Voltage	0V to 5.12V	080A
7	Cell 1 Voltage	0V to 5.12V	0811
8	Cell 2 Voltage	0V to 5.12V	0812
9	Cell 3 Voltage	0V to 5.12V	0814
10	Cell 4 Voltage	0V to 5.12V	0817
11	Cell 5 Voltage	0V to 5.12V	0818
12	Cell 6 Voltage	0V to 5.12V	081B
13	Cell 7 Voltage	0V to 5.12V	081D
14	Cell 8 Voltage	0V to 5.12V	081E
15	Lowest Cell Voltage	0V to 5.12V	0871
16	Highest Cell Voltage	0V to 5.12V	0872

Bi-Level Telemetry

Bi-level telemetry can be requested on sub-addresses 18, 19 or 22.

First a 1553B receive command with one data word as defined in Table II, which specifies the telemetry item being requested, must be issued. After a minimum delay of 1.2ms, the data can be retrieved by sending a 1553B transmit command for one data word on the same sub-address on which the request was initiated.

BEU8635-08

Table II – Bi-level Telemetry

Item	Telemetry Title	Status	Reply Bit	1st Data Word of 1553B Receive Command (Hex)
1	Overvoltage Latch Status	1 = Set	D13	0C80

32-Word Telemetry

To reduce data bus bandwidth usage, the 8635-08 supports a 32-word telemetry request on sub-address 20 as defined in Table III.

First a 1553B receive command with one data word of AAAA(Hex) must be issued. After a minimum delay of 1.2ms, the data can be retrieved by sending a 1553B transmit command for 32 data words on sub-address 20.

Reply word 31 is a modulo-16 message count. This counter increments by one for each valid telemetry request.

The 12-bit analog data reply is left justified in the 16-bit 1553B data word with the four LSBs set to "0".

BEU8635-08

Table III – 32-Word Telemetry

Item	Telemetry Title	Telemetry Type	Reply Word	Reply Bits
1	4V Reference	Analog	1	D(15:4)
2	Total Battery Voltage 1	Analog	2	D(15:4)
3	Total Battery Voltage 2	Analog	3	D(15:4)
4	Total Battery Voltage 3	Analog	4	D(15:4)
5	Share Bus Voltage	Analog	5	D(15:4)
6	Reserved	-	6	-
7	Cell 1 Voltage	Analog	7	D(15:4)
8	Cell 2 Voltage	Analog	8	D(15:4)
9	Cell 3 Voltage	Analog	9	D(15:4)
10	Cell 4 Voltage	Analog	10	D(15:4)
11	Cell 5 Voltage	Analog	11	D(15:4)
12	Cell 6 Voltage	Analog	12	D(15:4)
13	Cell 7 Voltage	Analog	13	D(15:4)
14	Cell 8 Voltage	Analog	14	D(15:4)
15	Reserved	-	15	-
16	Reserved	-	16	-
17	Reserved	-	17	-
18	Reserved	-	18	-
19	Reserved	-	19	-
20	Reserved	-	20	-
21	Reserved	-	21	-
22	Reserved	-	22	-
23	Reserved	-	23	-
24	Reserved	-	24	-
25	Reserved	-	25	-
26	Reserved	-	26	-
27	Reserved	-	27	-
28	Reserved	-	28	-
29	Reserved	-	29	-
30	Reserved	-	30	-
31	Message Count	Analog	31	D(15:0)
32	Overvoltage Latch Status	Bi-level	32	D13

BEU8635-08

8-Word Telemetry

To reduce data bus bandwidth usage, the 8635-08 supports an 8-word telemetry request on sub-address 24 as defined in Table IV.

First a 1553B receive command with one data word of 5555(Hex) must be issued. After a minimum delay of 1.2ms, the data can be retrieved by sending a 1553B transmit command for 8 data words on sub-address 24.

Reply word 8 is a modulo-16 message count. This counter increments by one for each valid telemetry request.

The 12-bit analog data reply is left justified in the 16-bit 1553B data word with the four LSBs set to "0".

Table IV – 8-Word Telemetry

Item	Telemetry Title	Telemetry Type	Reply Word	Reply Bits
1	Overvoltage Level Status	Bi-Level	1	D13
2	Reserved	-	2	-
3	Reserved	-	3	-
4	Reserved	-	4	-
5	0V Reference	Analog	5	D(15:4)
6	Lowest Cell Voltage	Analog	6	D(15:4)
7	Highest Cell Voltage	Analog	7	D(15:4)
8	Message Count	Analog	8	D(15:0)

BEU8635-08

Additional Commands

Data Load Command

1553B receive commands consist of 2 data words to the sub-address specified in Table V. Only the first data word is used.

Table V – Commands

Item	Function Title	Sub-Address	1 st Data Word of 1553B Receive Command (Hex)
1	Reserved	13	-
2	Reserved	14	-
3	Reset OVP Latch	15	0400

Telemetry Frame Sync Command

1553B broadcast command on sub-address 17 (any data word) commands the 8635-08 to refresh its RT address.

Remote Terminal State Command

1553B transmit command on sub-address 21 for one data word. The reply word will be 4000(Hex), to indicate that the unit is ready to accept another command or 5000(Hex), to indicate that the unit is busy and cannot accept another command.

1553B Data Wrap Around

Sub-address 30 is dedicated to data wrap around as specified in MIL-STD-1553B.

Supported Mode Codes

The 8635-08 supports the 1553B Mode Codes in Table VI.

Table VI – 1553B Mode Codes

Mode Code Name	Mode Code Number
Transmit Status Word	2
Transmitter Shutdown	4
Override Transmitter Shutdown	5
Reset Remote Terminal	8

1553B Status Flag Bits

The 8635-08 supports the following 1553B status flag bits:

- 1) Message Error bit
- 2) Broadcast Message Received bit

All other status bits are set to "0".

BEU8635-08

Connector P1 26 Pin Subminiature-D Plug Cell Sense

Pin #	Function Name	Pin #	Function Name
23	RESERVED	17	RESERVED
9	RESERVED	7	RESERVED
3	RESERVED	14	RESERVED
19	RESERVED	1	RESERVED
10	CELL_8+	20	RESERVED
13	CELL_7+	12	RESERVED
16	CELL_6+	18	RESERVED
26	CELL_5+	8	RESERVED
5	CELL_4+	4	RESERVED
2	CELL_3+	21	RESERVED
15	CELL_2+	22	RESERVED
24	CELL_1+	6	RESERVED
11	CELL_1-	25	RESERVED

Connector J2 for Control Board Triaxial 1553B Bus A

CHA_DATA_H
CHA_DATA_L
SHIELD

Connector J3 for Control Board Triaxial 1553B Bus B

CHB_DATA_H
CHB_DATA_L
SHIELD

BEU8635-08

Connector J1 for Control Board 51 Pin Micro-D Receptacle Control & Test Points

Pin #	Function	Pin #	Function	Pin #	Function
1	30V_RTN	18	V_BAT_3	35	V_BAT_2
2	NC_ISOLATION	19	NC_ISOLATION	36	NC_ISOLATION
3	NC_ISOLATION	20	+30V_POWER	37	NC_ISOLATION
4	NC_ISOLATION	21	+30V_POWER	38	NC_ISOLATION
5	30V_RTN	22	NC_ISOLATION	39	SPARE
6	NC_ISOLATION	23	NC_ISOLATION	40	CHASSIS GND
7	CHASSIS GND	24	CHASSIS GND	41	RESERVED
8	CELL_CHG_8	25	LOW_CELL	42	SPARE
9	SPARE	26	RESERVED	43	BEU_ON_CMD_1
10	BEU_OFF_CMD_2	27	BAL_ON_1	44	BEU_ON_CMD_2
11	BEU_OFF_CMD_1	28	BAL_ON_2	45	HIGH_CELL
12	RTA_2	29	RTA_0	46	RTA_4
13	RTA_GND	30	RTA_GND	47	RTA_GND
14	RTA_GND	31	RTA_GND	48	RTA_GND
15	RTA_1	32	RTA_3	49	RTPTY
16	OV_PROT	33	V_BAT_TP	50	V_BAT_RTN1
17	V_BAT_RTN3	34	V_BAT_RTN2	51	V_BAT_1

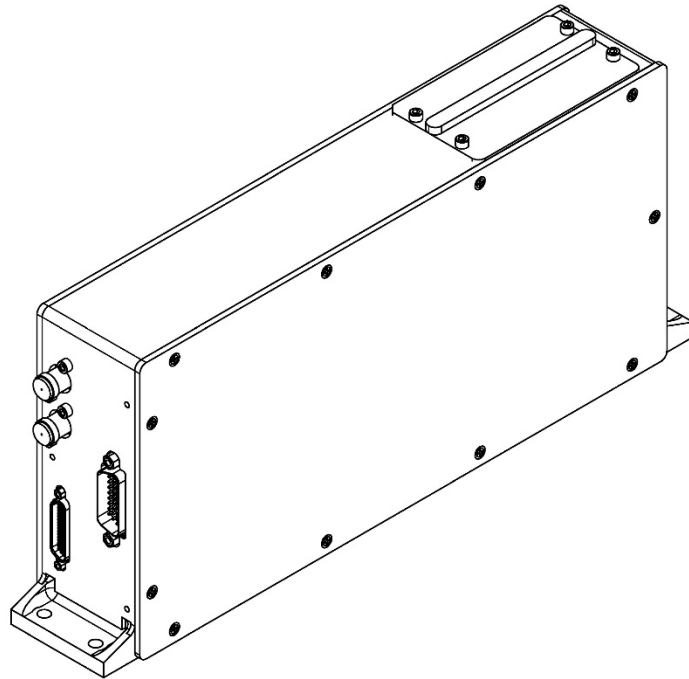

3-D View

BEU8635-08

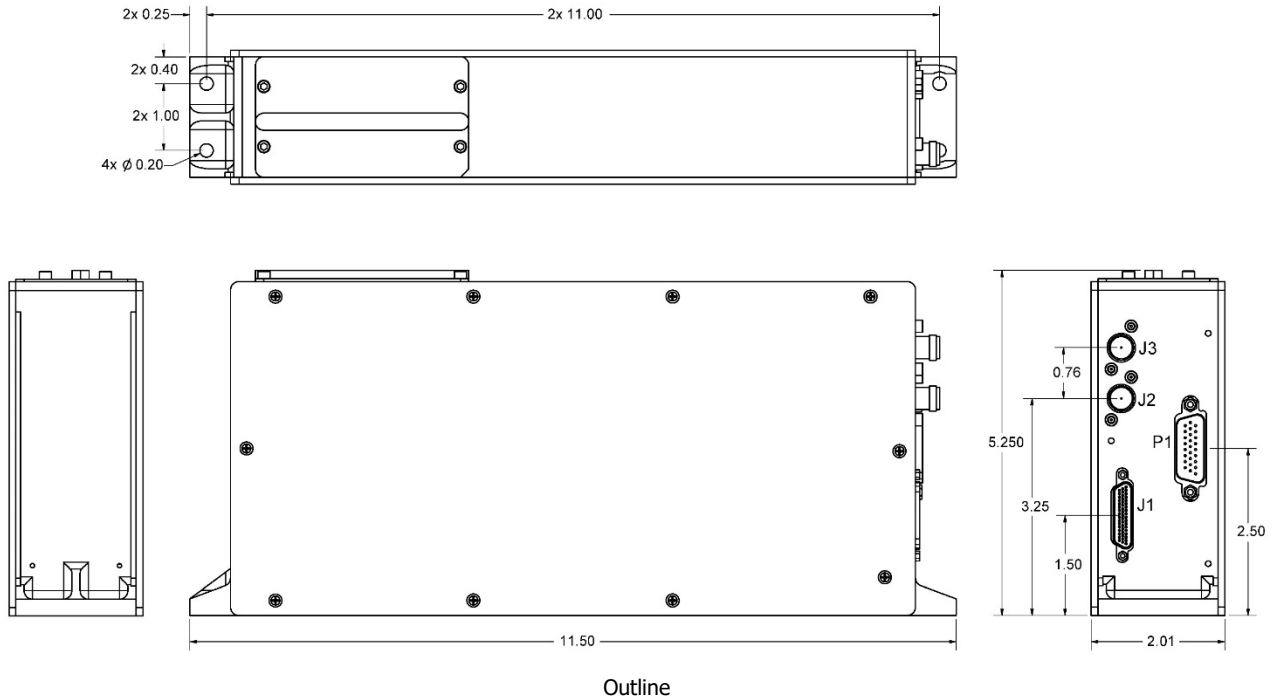

Standard Configuration

Power Dissipation

6.6 Watts from 30V Supply
0.5 Watts from battery

Operating Base Plate Temperature

BEU8635-08-S -34°C to +71°C
BEU8635-08 0°C to +70°C

Storage Temperature

-34°C to +71°C

Dimensions

11.5" L x 2.01" W x 5.25" H

Weight

3.5 lbs (1.59 kg)

Ordering Information

Model Number	Screening
BEU8635-08-S	High Reliability Space Grade
BEU8635-08	Commercial Flow

BEU8635-08

Datasheet Definitions

	DEFINITION
Advanced Datasheet	CAES reserves the right to make changes to any products and services described herein at any time without notice. The product is still in the development stage and the datasheet is subject to change . Specifications can be TBD and the part package and pinout are not final .
Preliminary Datasheet	CAES reserves the right to make changes to any products and services described herein at any time without notice. The product is in the characterization stage and prototypes are available.
Datasheet	Product is in production and any changes to the product and services described herein will follow a formal customer notification process for form, fit or function changes.

The following United States (U.S.) Department of Commerce statement shall be applicable if these commodities, technology, or software are exported from the U.S.: These commodities, technology, or software were exported from the United States in accordance with the Export Administration Regulations. Diversion contrary to U.S. law is prohibited.

Cobham Long Island Inc. d/b/a Cobham Advanced Electronic Solutions (CAES) reserves the right to make changes to any products and services described herein at any time without notice. Consult an authorized sales representative to verify that the information in this data sheet is current before using this product. The company does not assume any responsibility or liability arising out of the application or use of any product or service described herein, except as expressly agreed to in writing; nor does the purchase, lease, or use of a product or service convey a license under any patent rights, copyrights, trademark rights, or any other of the intellectual rights of the company or of third parties.