



FRONTGRADE

APPLICATION NOTE

UTMC's RadHard MSI

Decoupling Techniques for UTMC's
RadHard MSI Product Family

10/30/2023

Version #: 1.0.0

Decoupling Techniques for Frontgrade's RadHard MSI Product Family

The primary purpose of the decoupling capacitor is to supply output switching charge for a semi-conductor device. The switching charge allows the outputs to discharge and charge loads capacitance from either logic high-to-low or logic low-to-high. Inadequate sizing and power location of power supply decoupling capacitors can result in numerous board problems. The most common problem associated with inadequate decoupling capacitance is power supply noise (i.e, high frequency noise and or droop). If the decoupling capacitor does not support the switching charge requirements of the device, the power supply must deliver the additional charge (i.e., current). Proper decoupling requires the available decoupling charge Q_{DEC} equal or exceed the required switching charge Q_S .

The additional switching current flowing from the power supply to the device on a printed circuit board (PCB) trace creates a voltage drop between the supply and device. A typical PCB trace has an inductance of approximately 17nH per inch (PCB board specific). The trace inductance, distance between power supply and device, and current dI/dT determines the magnitude of the voltage drop along the trace and at the V_{DD} input pin. Large voltage drops can result in data loss and intermittent circuit functionality. Figure 1 is a circuit diagram showing load capacitance and decoupling capacitance

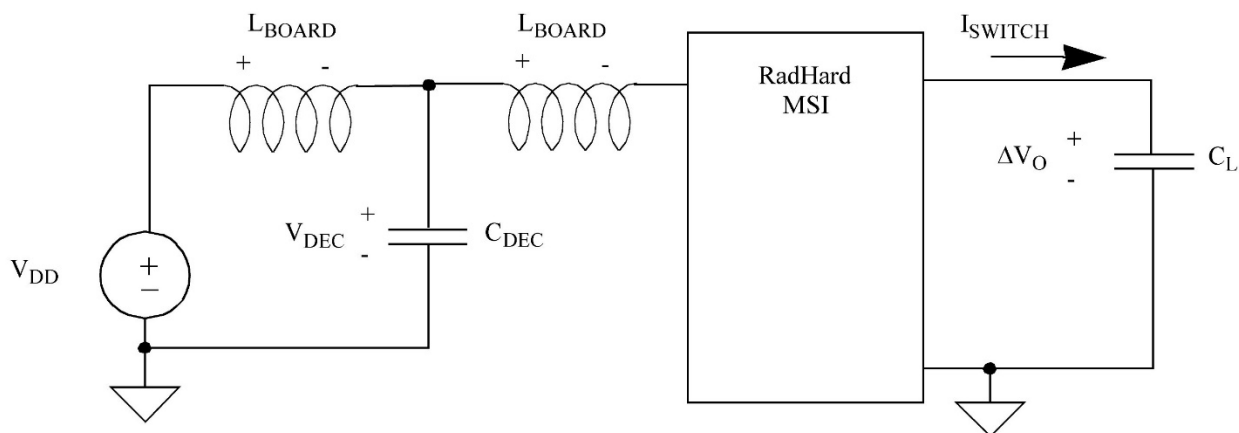

Figure 1: Circuit Diagram

Use the following technique to determine the total switching charge requirements (Q_S) and decoupling capacitor size (C_{DEC}):

C_T defines the total load capacitance switching on a clock edge. Calculate C_T by multiplying the number of outputs switching on a clock edge by the load capacitance (assumes equal output loading). Frontgrade RadHard MSI family is characterized with a C_L of 50pF.

ΔV_O defines the voltage swing for the switching output(s). Calculate ΔV_O using either of the following equations:

$\Delta V_O = V_{OH} - V_{OL}$ for best case or $V_{DD} - V_{SS}$ (or ground) for worst case.

Q_S defines the total charge required to support output switching. Use the equation $Q_S = (\Delta V_O \times C_T)$ to calculate the switching charge requirements.

Next calculate the size decoupling capacitor size. The decoupling capacitor can deliver a charge of Q_{DEC} which equal C_{DEC} multiplied by V_{DD} in Figure 1. To limit power supply ripple limit ΔV_{DEC} deviations to 250mV. To accomplish the 250mV ripple goal, Q_{DEC} is equal to C_{DEC} multiplied by ΔV_{DEC} , where ΔV_{DEC} equals 250mV.

Equating Q_{DEC} to Q_S one can write the following:

- $Q_S = Q_{DEC}$
- $\Delta V_O \times C_T = \Delta V_{DEC} \times C_{DEC}$

Example:

Calculate Q_S and C_{DEC} for 5 outputs switching 50pf worst case (VDD = 5.5 volts)

- $Q_S = \Delta V_O \times C_T$
- $Q_S = (5 \times 50\text{pf} \times 5.5)$ coulombs (Q)
- $Q_S = 1.37 \times 10^{12}$ q or 1.37nQ

Since $\Delta V_O \times C_T = \Delta V_{DEC} \times C_{DEC}$

- $C_{DEC} = Q_S / \Delta V_{DEC}$
- $C_{DEC} = 1.37\text{nQ} / 250\text{mV}$
- $C_{DEC} = 5.5$ nf

Revision History

| Date | Revision # | Author | Change Description | Page # |
|------|------------|--------|--------------------|--------|
| | | | | |
| | | | | |
| | | | | |
| | | | | |

Frontgrade Technologies Proprietary Information Frontgrade Technologies (Frontgrade or Company) reserves the right to make changes to any products and services described herein at any time without notice. Consult a Frontgrade sales representative to verify that the information contained herein is current before using the product described herein. Frontgrade does not assume any responsibility or liability arising out of the application or use of any product or service described herein, except as expressly agreed to in writing by the Company; nor does the purchase, lease, or use of a product or service convey a license to any patents, rights, copyrights, trademark rights, or any other intellectual property rights of the Company or any third party.